

WATERPROOF PLATFORM SCALES

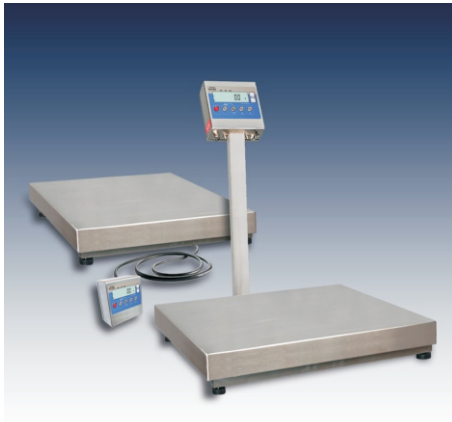

Wessex Scale Co



Waterproof platform scales are designed for operation in environment with high humidity and in direct contact with water.

They are equipped with measuring indicator series PUE C31 H with backlit LCD indicator and IP rating 68. Indicator is installed on a pillar attached to the weighing platform, optionally, the indicator can be connected to the platform by 3 meter long cable; in this solution it is possible to hang the indicator on wall.

Scale is manufactured in stainless steel technology type OH18N9.



Counting pieces



Checkweighing



Summing function

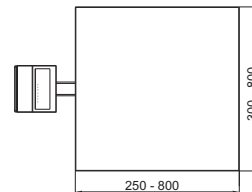
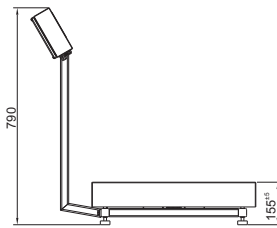

Waterproof scales are equipped with 100 % waterproof protection of load cell. this construction secures load cells against the influence of external factors.

Technical data:

	WPT 6H2	WPT 15H2	WPT 15H3	WPT 30H3	WPT 60H3	WPT 150H3
	WPT 6H2/K	WPT 15H2/K	WPT 15H3/K	WPT 30H3/K	WPT 60H3/K	WPT 150H3/K
Max capacity	6 kg	15 kg	15 kg	30 kg	60 kg	150 kg
Readability	2 g	5 g	5 g	10 g	20 g	50 g
Tare range	-6 kg	-15 kg	-15 kg	-30 kg		
Pan size	250×300 mm	250×300 mm	410×410 mm	410×410 mm	410×410 mm	410×410 mm
Working temperature	-10° - +40 °C					
Output signal	RS 232					
IP rating	IP 66/67					
Power supply	230V AC, 50Hz / 11V AC and batteries					
Display	LCD					
Mass	5,6 kg	5,6 kg	13 kg	13 kg	13 kg	13 kg

Technical data:

	WPT 60H4	WPT150H4	WPT 60H5	WPT 150H5	WPT 300H5	WPT 150H6	WPT 300H6
	WPT 60H4/K	WPT150H4/K	WPT 60H5/K	WPT 150H5/K	WPT 300H5/K	WPT 150H6/K	WPT 300H6/K
Max capacity	60 kg	150 kg	60 kg	150 kg	300 kg	150 kg	300 kg
Readability	20 g	50 g	20 g	50 g	100 g	50 g	100 g
Tare range	-60 kg	-150 kg	-60 kg	-150 kg	-300 kg	-150 kg	-300 kg
Pan size	500×500 mm	500×500 mm	600×600 mm	600×600 mm	600×600 mm	800×800 mm	800×800 mm
Working temperature	-10° - +40 °C						
Output signal	RS 232						
IP rating	IP 66/67						
Power supply	230V AC, 50Hz / 11V AC and batteries						
Display	LCD						
Mass	19 kg	19 kg	22 kg	22 kg	22 kg	42 kg	42 kg

WATERPROOF PLATFORM SCALES



Wessex Scale Co



Capacity range for Radwag waterproof platform scales ranges from 3 kg / 1 g to 300 kg / 100 g. Power supply from mains, RS 232 output is offered as standard equipment of the scale.

Optionally, for additional charge it is possible to manufacture stainless steel waterproof scales with upgraded protection against corrosion.

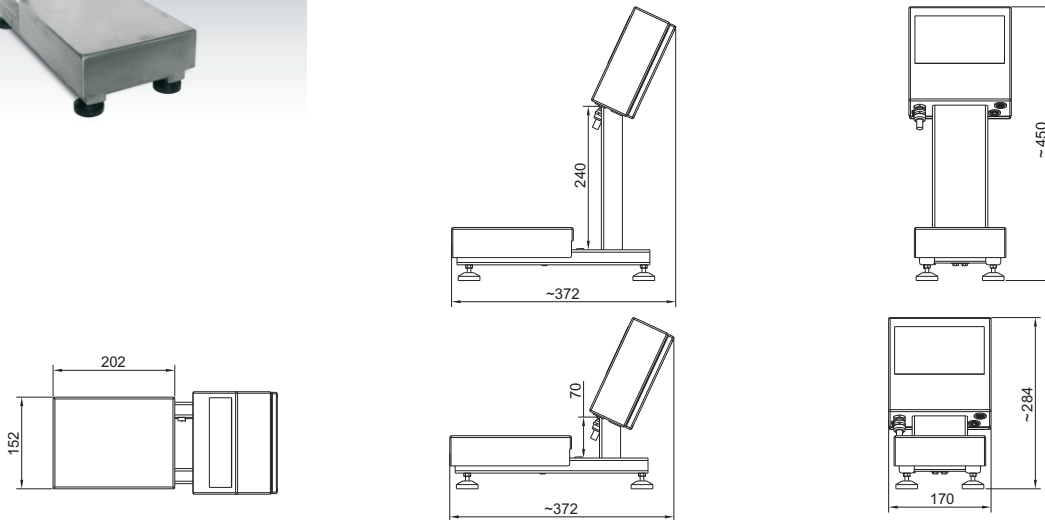

Technical data:

	WPT 3H1 WPT 3H1/K
Max capacity	3 kg
Readability	1 g
Tare range	-3 kg
Pan size	200×150 mm
Working temperature	-10° - +40 °C
Output signal	RS 232
IP rating	IP 66/67
Power supply	230V AC, 50Hz / 11V AC and batteries
Display	LCD
Mass	4 kg

Additional equipment:

- RACK FOR HEAD
- HANDLE TO STEEL HEAD TO MOUNT IT TO WALL/TABLE
- LCD DISPLAY
- LARGE SIZE DISPLAY
- "KAFKA" THERMAL PRINTER
- NEEDLE PRINTER "EPSON"
- TABLE FOR SCALE
- ROLL COVER
- COMPUTER SOFTWARE: PW-WIN 2005
- COMPUTER SOFTWARE: RAD-KEY 2000
- COMPUTER SOFTWARE: REC-FS 2000
- COMPUTER SOFTWARE: LS-FS 2000
- RS 232/RS 485 CONVERTER
- EXTERNAL POWER OUTPUT

Supplied by

Wessex Scale Co,

Lower Mill, Exford Nr Minehead Somerset TA24 7QE
 Tel: 0845 472 5345 Fax: 01643 800 299
 Email: sales@wessexscales.co.uk
 Website: www.wessexscales.co.uk