



Wessex Scale Co **Valor™ 3000 Xtreme**  
Compact Precision Scales



***Rugged, full stainless steel design in a high performance, easy-to-use, portable scale.***

The Valor™ 3000 Xtreme Compact Precision Scale continues the OHAUS tradition of building high quality, durable products that are easy to use and hard to beat. The Valor 3000 Xtreme takes these OHAUS virtues to a new level by offering high precision 20,000d readability, durability, and ease-of-use, encased in a sleek and fully stainless steel compact housing. Washdown versions and OIML / EC Type Approved models ensure that the Valor 3000 Xtreme meets the needs of even the most demanding environments.

***Standard Features Include:***

- **Extreme Design** – Full stainless steel housing with added chemical resistance and removable stainless steel weighing pan are durable and easy to clean (*IP65 water resistant models available*)
- **Extreme Protection** – Technically advanced overload protection rated at 10x capacity is ideal for tough environments where capacity is frequently exceeded
- **Extreme Performance** – The Valor 3000 Xtreme offers resolutions up to 20,000d and 0.01g, providing precise measurements in demanding environments. User adjustable filtering and stability settings allow the Valor 3000 Xtreme to operate accurately in drafty and unstable conditions
- **Extremely Friendly** – OHAUS' SmarText™ user interface utilizes a bright backlit LCD and simple text prompts to guide users through application use and scale setup making the Valor 3000 Xtreme very easy to use

# Valor™ 3000 Xtreme Compact Precision

## Extreme Design

Extreme design means OHAUS took a clean sheet design and focused on offering the most durable and portable portioning product available. The Valor 3000 Xtreme is the highest precision scale in its class with complete stainless steel construction – both top and bottom housings are made of T304 stainless steel.



For use in wet applications, the Valor 3000 Xtreme offers an even higher level of protection by offering full IP65 water resistant models. All Valor 3000 Xtreme models are NSF listed/certified, and will support a HACCP certified system. Valor 3000 Xtreme is battery powered for maximum portability and convenience. Valor 3000 Xtreme features QuadraStance™, with four wide adjustable feet to ensure that the scale stays ultra-secure and slip free during operation in wet or dry conditions, on any surface.



## Extreme Overload and Shock Protection

All OHAUS products are designed to be the most rugged and durable products on the market, and the Valor 3000 Xtreme is no exception. Leveraging advanced overload and shock resistance technology, OHAUS designed the Valor 3000 Xtreme's overload protection system to provide ten times capacity overload protection. This extreme overload protection makes each Valor 3000 Xtreme ideal for tough environments where scale capacity is exceeded regularly.

## Extreme Performance

The Valor 3000 Xtreme has a rugged design, combined with high precision weighing cells offering resolutions up to 20,000d. Every scale has user adjustable stability, filtering and auto zero settings allowing Valor 3000 Xtreme to operate in drafty and unstable environments.



## Extremely Friendly

Every Valor 3000 Xtreme is designed with OHAUS' SmarText™ interface that utilizes a bright backlit LCD and simple English text prompts to guide users through application use and scale setup.

## Outline Dimensions

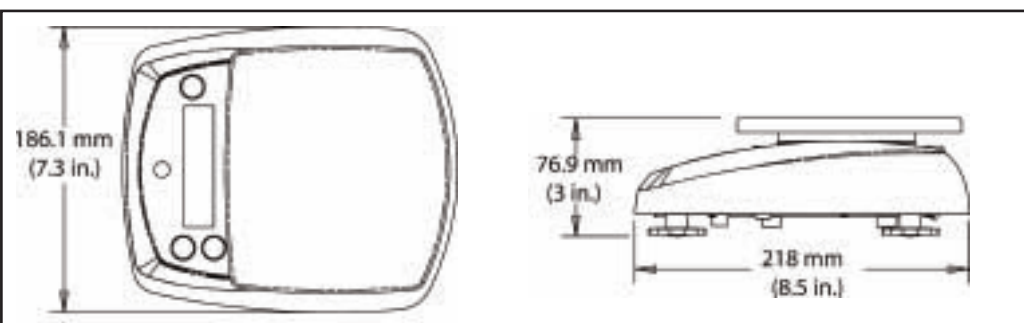

## Application Modes

The Valor 3000 Xtreme series is loaded with software specifically designed for simple use and maximum throughput. Application modes include:

**Percentage Weighing** – This mode is great for compounding, mixing ingredients and formulation allowing users to compare the weight of a sample as a percentage of a reference weight. This function allows for quick portioning and checking of multiple samples against a target, and for quickly preparing multiple samples of the same size. The Valor 3000 Xtreme can automatically compute Baker's Percentages, eliminating guesswork and speeding use.



**Specific Gravity Determination** – This mode is perfect for rapidly and easily determining the specific gravity of a sample without the need for manual calculations. Not only can this be critical in materials testing, it is also useful for checking aeration of mixes for food processing and foodservice applications.

## Other Standard Features

### AC Power Standard

The included AC adapter provides continuous power, and the convenient stow-away plug keeps moisture out when not in use



### Stainless Steel Housing and Weighing Pan

Easy to wipe clean and keep sanitary. NSF listed/certified, Valor 3000 Xtreme supports HACCP compliance



### Optional Type Approvals

OIML / EC Type Approved models are available for Legal for Trade applications (contact OHAUS for information)



### Long Battery Life

Valor 3000 Xtreme will run up to 120 hours with four C-type batteries



### Bright Backlit Display

Weighing results are clearly shown on the bright backlit display with large easy-to-read digits

### IP65 Housing

Valor 3000 Xtreme W is perfect for use in wet and damp environments



### Up Front Level Bubble

A glance at the level bubble (XW models only) ensures easy leveling and superior stability

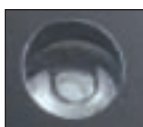

### Quadrastance™ for Superior Stability

OHAUS Quadrastance incorporates four rugged, adjustable feet to help prevent slippage on wet or uneven surfaces



### SmartText™ Software

OHAUS' easy-to-use interface guides you through setup and applications such as Percentage Weighing and Specific Gravity modes with a simple push of the button



# Valor™ 3000 Xtreme Compact Scales

## Specifications

Models (non Approved)	V31XH202	V31XH2	V31X3	V31X6	V31XW301	V31XW3	V31XW6
Models (OIML / EC Type Approved)	---	---	---	---	V31XW301M	V31XW3M	V31XW6M
Capacity (g)	200	2000	3000	6000	300	3000	6000
Readability (g)	0.01	0.1	1	1	0.1	0.5	1
Readability (g), OIML / EC Type Approved	NA	NA	NA	NA	0.2	1	2
Weighing Units	lb, decimal or fractional oz, lb:oz, fluid oz (of water), kg, g						
Modes	Simple weighing, percent weighing, combined zero/tare, specific gravity (S)						
Keyboard	Three mechanical switches (1 left; 2 right)						
Calibration	Digital external span calibration						
Display	7 segment, 6 digit, 20mm high LCD with white LED backlight						
Display Indicators	Center of zero, stability, over/under load, weighing unit and battery status						
Tare Range	Full capacity by subtraction						
Stabilization Time	3 seconds or less						
Auto-Zero Tracking	Off, 0.5, 1 or 3 divisions						
Operating Temp. / humidity	0°C to 40°C at 10% to 95% relative humidity Non-condensing, up to 4000m above sea level						
Power	9 VDC 0.5A AC wall adapter, 50.60 Hz (included) or four 1.5 volt "C" batteries (not included)						
Battery Life	50 hours with alkaline cells	120 hours with alkaline cells			50 hours with alkaline cells		
Dimensions L x W x H	218 x 186 x 77 mm						
Pan size L x W	120 mm dia.	146 x 158 mm					
Carton Dimensions L x W x H	325mm L x 252mm W x 140mm H						
Net Weight	1.2 kg	1.3 kg			1.4 kg		
Shipping Weight	2 kg	2.1 kg			2.2 kg		
Ingress Protection	---	---	---	---	IP65	IP65	IP65

## Standard Features

Removable stainless steel pan, digital external calibration software, selectable environmental settings, fast stabilization with selectable Auto-tare, integrated level bubble (select models) and adjustable feet, bright backlight display, selectable Auto-Off, selectable weighing unit, selectable power-up unit, included AC power adapter, OIML / EC Type Approved models available (select models)

## Accessories

Oversize sandwich platter, french fry platter, ice cream platter, carrying case. Contact your local OHAUS representative for availability.

## Approvals

- **Food Service:** NSF Listed/Certified to NSF/ANSI 169-2005 *Special Purpose Food Equipment and Devices* (formerly NSF C-2); meets requirements for HACCP conformity.
- **Electrical/Emissions:** CE listed, meets AS/NZS4251.1 Emission/AS/NZS4252.1 Immunity, FCC Class B Part 15 operation, Industry Canada Class A.  $cUL_{US}$  AC power pack.  
Compliant to Directive 2002/95/EC on the restriction of the use of certain hazardous substances in electrical and electronic equipment (ROHS).  
Compliant to Directive 2002/96/EC on waste electrical and electronic equipment (WEEE).
- **Approved/Legal-for-Trade:** OIML / EC Type Approved R76 Class III and EC Type Approval. Contact your local OHAUS representative for availability.
- **Quality:** Ohaus quality management system registered to ISO 9001:2000

Supplied by,

Wessex Scale Co, Lower Mill, Exford Nr Minehead Somerset TA24 7QE  
Tel: 0845 472 5345 Fax: 01643 800 299 Email: sales@wessexscales.co.uk  
Website: www.wessexscales.co.uk

\* ISO 9001:2000  
Registered Quality Management System

80774932 © Copyright Ohaus Corporation

