

# Series T66

## Cantilever beam load cell for harsh industrial environments

capacities 10kg to 200kg



Stainless steel load sensor

3000 divisions OIML R60 Class C

Hermetically sealed,  
fully welded construction

5 year warranty

Ease of installation

High integrity cable entry

Sealed to IP68

available in   
and high temperature versions

This fully welded stainless steel load cell is hermetically sealed to IP68 and can be used in the harshest industrial environments. It is suitable for weighing platforms, bag fillers, belt weighers and tank weighing in the Food Processing, Chemical, Pharmaceutical and general Bulk Handling industries.

T66 load cells are available with intrinsically safe certification ATEX EEx ia IIC T6 for both Dust and Gas in all zones. High temperature variants for operation in environments up to 150°C are also available.

# technical specification sheet

## Series T66

	Load Cell Capacities	Units
	10, 20, 50, 100, 200	kg
Rated Output	2	mV/V±0.1%
Accuracy Class	3000	n.OIML
Combined Error	<±0.017	%*
Non-repeatability	<±0.015	%*
Creep (30 minutes)	<±0.016	%*
Temperature Effect on Zero Balance	<±0.01	%*/°C
Temperature Effect on Span	<±0.006	%*/°C
Compensated Temperature Range	-10 to +40	°C
Operating Temperature Range	-20 to +50	°C
Safe Overload	150	%*
Ultimate Overload	200	%*
Zero Balance	<±1	%*
Input Resistance	400	Ω ± 20
Output Resistance	350	Ω ± 3
Insulation Resistance	>5000	MΩ @ 100v
Recommended Supply Voltage	10	V
Maximum Supply Voltage	15	V

\*With respect to rated output

### AV Mount



### LeverMount® Lite



### Tension accessories

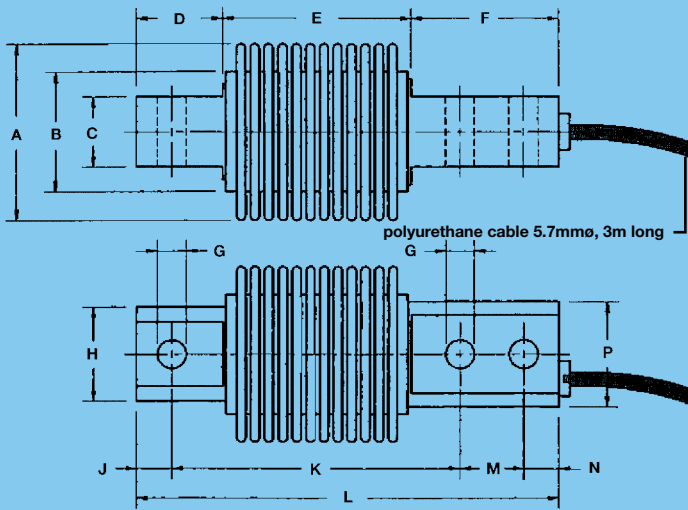

Our policy is one of continuous product enhancement. We therefore reserve the right to incorporate technical modifications without prior notification.

### Distributed by

Wessex Scale Co  
 Lower Mill, Exford Nr Minehead  
 Somerset TA24 7QE  
 Tel: 0845 472 5345  
 Fax: 01643 800 299  
 Email: sales@wessexscales.co.uk  
 Website: www.wessexscales.co.uk

Range (kg)	øA	øB	C	D	E	F	øG	øH	J	K	L	M	N	øP
10 - 300	42	34	20	24.5	53.5	42	8.2	27	10	82	120	18	10	30

All dimensions in mm.

### Electrical Connections

Via 4 core, 4m, 5.7mm dia., screened polyurethane cable.

Screen not connected electrically to load cell.

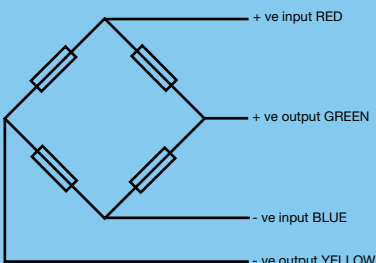

Nominal shipping weight = 1kg

### Construction

Load cell manufactured from 17-4PH stainless steel heat treated to H900 condition -1379N/mm<sup>2</sup> UTS.

### Options

Anti Vibration Loading Assembly  
 LeverMount® Lite Loading Assembly  
 Tension accessories

