

TSCALE

SCALES & BALANCES

NHB & NHB+ SERIES PORTABLE BALANCE

Wessex Scale Co

TECHNICAL DATA

- ◆ External resolution...Up to 100,000
- ◆ Keyboard.....7 keys
- ◆ Display.....16.5 mm LCD
- ◆ Operate temp.....0°C ~ +40°C
- ◆ ADC update.....≤ 1/10 second
- ◆ Rating.....AC adapter (9V/800mA)
Rechargeable battery (6V/1.2Ah)



FEATURES

- ◆ Capacity from 100g to 6000g
- ◆ 16.5mm LCD display, attached LED backlight and loading bar graph
- ◆ Rechargeable battery
- ◆ Selectable weighing unit
- ◆ Percentage weighing, counting, accumulation
- ◆ Draught shield with 100g / 600g / 1000g
- ◆ Standard RS-232 interface

DIMENSIONS (mm)

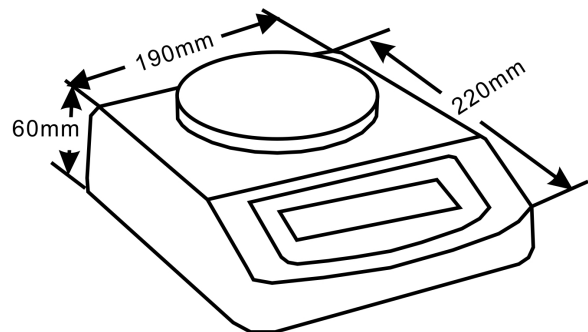

SPECIFICATIONS

MODEL	NHB	NHB+
Max division	60,000	100,000
Pan size	Φ 80mm(100g) Φ 120mm(600~1000g) Φ 135mm(6000 g)	
Display	16.5mm LCD backlight (on/off/auto selectable)	
Capacity	600g x 0.01g - 6000g x 0.1g	100g x 0.001g - 1000 x 0.01g
Internal counts	1,000,000	
Rating	AC adapter powered (9V/800mA) Internal rechargeable battery (6V/1.2Ah)	
Housing	ABS plastic	