

Wessex Scale Co

# Mini Weigher *plus*



100kg to 5t capacities



Rugged & weatherproof



High Accuracy



Audible setpoint alarm



Multi-range



Peak hold function



# Specifications

Supplied by, Wessex Scale Co, Lower Mill, Exford Nr Minehead Somerset TA24 7QE  
 Tel: 0845 472 5345 Fax: 01643 800 299 Email: sales@wessexscales.co.uk  
 Website: www.wessexscales.co.uk

## Mini Weigher Plus

Our most popular product, manufactured since 1987.

This crane scale will suit most lifting applications.

Available in capacities from 100kg to 5 tonnes.

All MWP's have push button control for: tare, units (kg, lbs, kN & t),  
 peak hold and pre-set tare.

Supplied with high quality Crosby hook and lifting eye.

All MWP's are fitted with an adjustable setpoint audible alarm.

Other fittings such as Gunnebo or rod ends are available on request.

Capacities up to 1 tonne supplied with carry case.

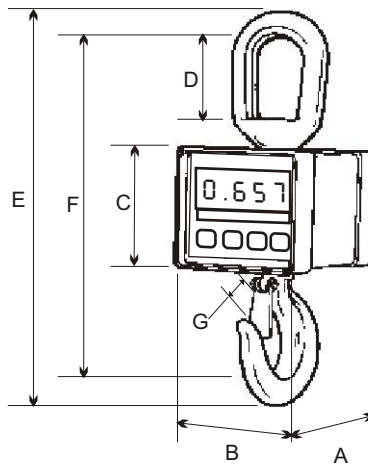

## Specifications

Part Number	MWP/100	MWP/250	MWP/500	MWP/1T	MWP/2T	MWP/5T
Capacity	100kg	250kg	500kg	1,000kg	2,000kg	5,000kg
Resolution	0.05kg	0.1kg	0.2kg	0.5kg	1kg	1kg
Weight	1.5kg	1.5kg	1.5kg	1.5kg	3.1kg	8.7kg
Safety Factor	10:1	5:1	5:1	5:1	5:1	5:1
Protection	IP65/NEMA 4					
Battery Type	9v PP3					
Battery Life	50hrs continuous					
Display Type	25mm LCD					
Operating Temp	-10 to 50c					
Accuracy	+/- 0.3%					
Dimension A	82mm	82mm	82mm	82mm	117mm	136mm
Dimension B	113mm	113mm	113mm	113mm	112mm	112mm
Dimension C	81mm	81mm	81mm	81mm	92mm	92mm
Dimension D	50mm	50mm	50mm	50mm	64mm	98mm
Dimension E	240mm	240mm	240mm	240mm	320mm	444mm
Dimension F	208mm	208mm	208mm	208mm	271mm	365mm
Dimension G	22mm	22mm	22mm	22mm	28mm	42mm