

# LeverMount®

**Unique, patented and cost effective solution for process weighing applications**

*capacities 10kg 20kg, 50kg, 100kg, 200kg, 300kg, 500kg 1000kg, 2000kg, 3000kg and 5000kg*



**Purpose designed stainless load cell and mount arrangement**

**LeverMount® can be raised and lowered under load without jacking**

**Load cell removal without jacking or dummies**

**Straightforward, low cost installation without specialist tooling**

**Highly stable three point mounting**

**Substantial lift off prevention**

**Easily configurable for radial or tangential mounting**

**Tolerant of steel work misalignment**

**Allows for vessel expansion and contraction**

**Stainless steel OIML C3 approved load cell, fully welded, sealed to IP68**

LeverMount® is the latest development in load cell weighing assemblies from Thames Side Sensors. Process weighing installations are made easier, safer and more cost effective using this simple, innovative design.

Load cells approved to 3000 divisions OIML R60 Class C.

Available with ATEX certification for hazardous area applications.

# LeverMount® - Innovation from Thames Side-Sensors Ltd

The concept of a purpose designed loading assembly using single ended shear beam load cells for vessel weighing was first introduced in the early 1980's. LeverMount® is the latest generation of load cell weighing assemblies from Thames Side Sensors, specifically designed to offer a completely fresh approach to process weighing solutions.

Utilising the established range of Thames Side shear beam and bending beam load cells, the patented LeverMount® retains all of the advantages of previous mount designs, whilst providing improved mechanical stability before, during and after installation.

The top plate of the LeverMount® can be raised and lowered under load without specialist tools. Additionally, the load cell can be removed or replaced without the need for external jacks or dummy load cells.



## UNIQUE & SIMPLE

Many other designs of mounting assembly provide a threaded jacking feature which allows a vessel to be supported by the mount prior to the installation of the load cells, however under most load conditions, an external jack is needed to raise and lower the vessel, and threads can become clogged with dirt or powder, rendering the integral jacking mechanism unusable, even under low loads.

LeverMount's® unique patented design is such that no separate support arrangements are necessary to raise and lower the vessel. The base casting itself provides a stable load-bearing platform prior to installation of the load cell. Once the vessel is in position and the two transit bolts are removed, the load cell is used as a lever to raise the top plate of the mount into the working position, regardless of whether the vessel is empty or full.

Removal of a load cell at any time is accomplished by reversing the procedure, and requires no jacks, dummy load cells or specialist tools. Installation, operation and maintenance of the vessel weighing system is consequently made safer, easier, swifter and less costly.

Load cells for use in the LeverMount® can be specified with ATEX EEx ia IIC T6 certification for both dust and gas in all zones as well as Ex nA II T6 gas only certification which allows Zone 2 use without safety barriers. High temperature versions are also available for operation up to 150°C utilising special high temperature components and PTFE Teflon cable. LeverMount® is just one product in an extensive range of innovative Thames Side load cell and mount arrangements, with capacities from 10kg up to 600 tonnes, designed specifically for process weighing and materials storage applications.

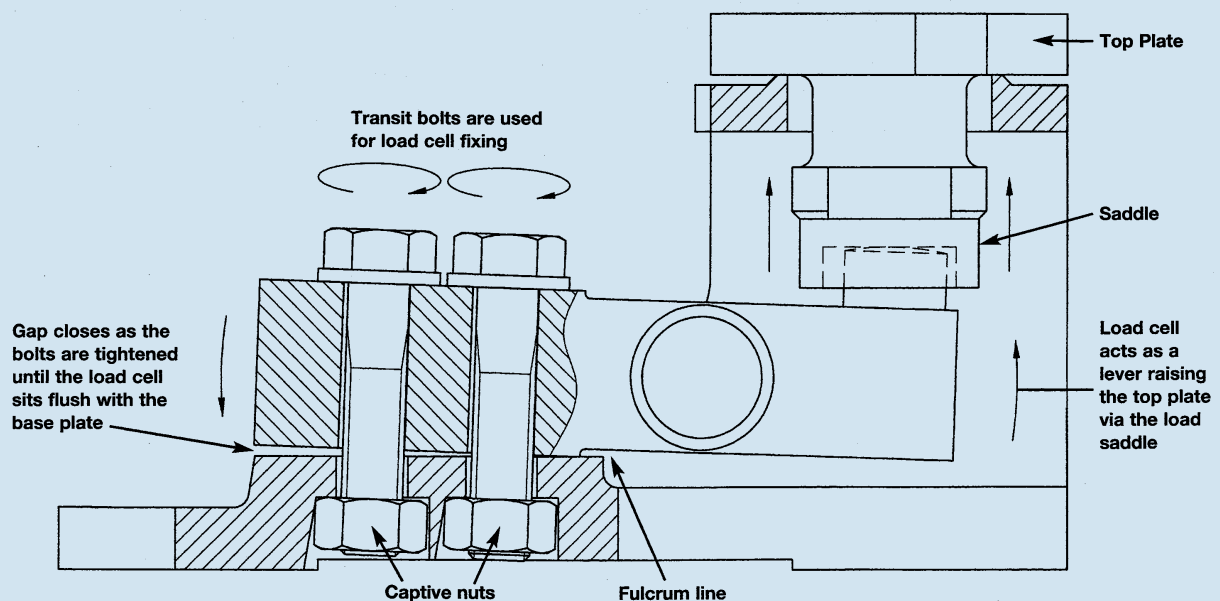

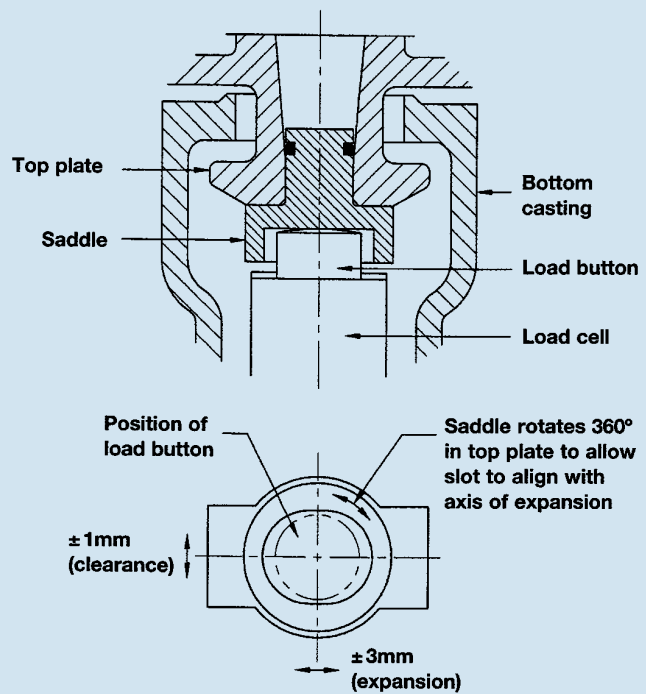
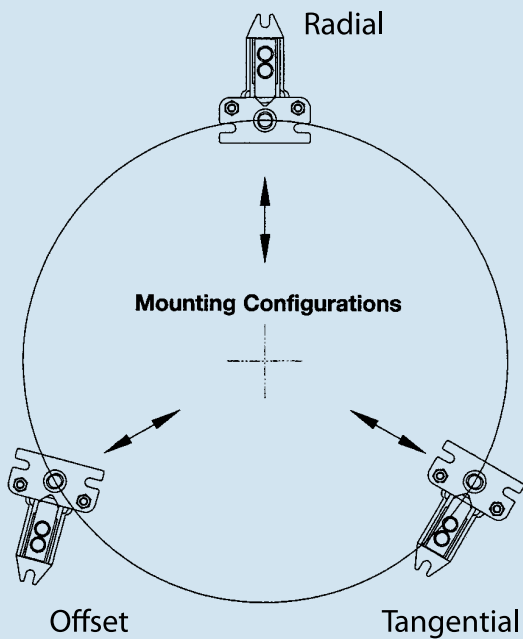

## FEATURES

- Purpose designed cast steel mount and stainless steel load cell
- Simple two part casting using the transit bolts with captivated nuts for load cell fixing
- Stainless steel, IP68, fully welded, single ended shear beam load cell
- Load cell acts as the lever to raise and lower the top plate and vessel
- Vessel can be raised and lowered under load
- No jacking screws or support pillars
- Three point support and fixing
- Top plate movement in the lateral and rotational axis
- Configurable for radial, tangential or offset mounting
- Substantial anti-lift facility
- Minimal difference between the working height and the installed height
- Load cell can be easily removed under load in situ
- Three physical sizes cover the range from 10kg to 5000kg

## BENEFITS

- Ideal for process weighing applications that require an accurate, safe and cost effective solution
- Aesthetically pleasing design, eliminating the need for additional machining and special bolts
- Suitable for use in the harshest of industrial environments
- No need for alternative lifting devices such as pad jacks
- Easier, quicker and safer than alternative mount arrangements
- No stripped threads or top plate interference
- Eliminates rocking and twisting in the mount, always finds a plane
- Tolerant of steel work misalignment avoiding any mechanically induced errors
- Easy alignment to the radial axis of the vessel to compensate for expansion and contraction.
- Increased safety
- Reduces the need to adjust for pipe work without flexible connections
- Less down time
- Covers the majority of process weighing applications

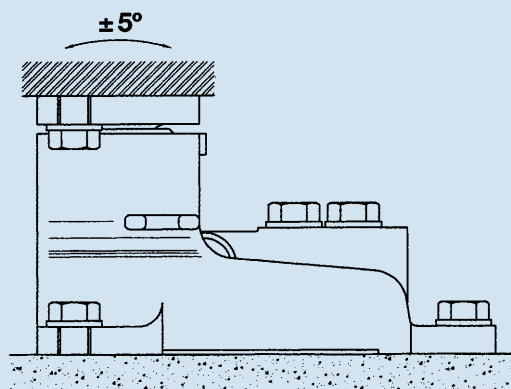
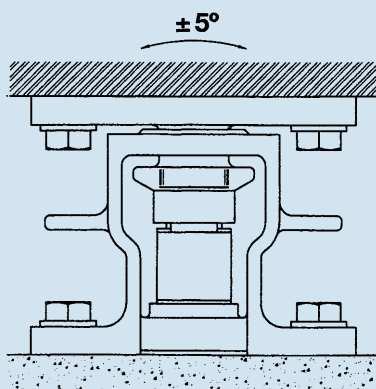

# LeverMount® - Innovation from Thames Side-Sensors Ltd

	LeverMount Lite	Units	LeverMount
<b>Load Cell Approval</b>	<b>Load Cell Specification</b> 3000 divisions (C3) OIML R60 Class C		<b>Load Cell Specification</b> 3000 divisions (C3) OIML R60 Class C
<b>Load Ranges</b>	10, 20,50,100 & 200	kg	300, 500, 1000, 2000, 3000 & 5000
<b>Rated Output</b>	2+/- 0.1%	mV/V	2±0.15%
<b>Combined Error</b>	<±0.017	%*	<±0.017
<b>Non-repeatability</b>	<±0.015	%*	<±0.015
<b>Creep (30 minutes)</b>	<±0.016	%*	<±0.016
<b>Temp Effect on Zero Balance</b>	<±0.01	%*/°C	<±0.01
<b>Temp Effect on Span</b>	<±0.006	%*/°C	<±0.006
<b>Compensated Temp Range</b>	-10 to +40	°C	-10 to +40
<b>Operating Temp Range</b>	-20 to +70	°C	-20 to +70
<b>Safe Overload</b>	150	%*	150
<b>Ultimate Overload</b>	300	%*	300
<b>Zero Balance</b>	<±1	%*	<±2
<b>Input Resistance</b>	400±20	ohms	400±20
<b>Output Resistance</b>	350±3	ohms	350±3
<b>Insulation Resistance</b>	>5000	Mohms @ 100V.dc	>5000
<b>Recommended Supply Voltage</b>	10	V	10
<b>Maximum Supply Voltage</b>	15	V	15
<b>Cable Length</b>	4	m	5
<b>Protection Class</b>	IP68		IP68

\*With respect to rated output

#### Shipping Weights: (kg)

10, 20, 50, 100, 200 = 1.2kg  
 300, 500, 1000, 2000 = 4 kg  
 3000, 5000 = 9 kg.

#### Construction

Mount manufactured from cast 316 stainless steel.  
 Load cell manufactured from high strength 17-4PH stainless steel, electro-polished, fully welded and sealed to IP68.

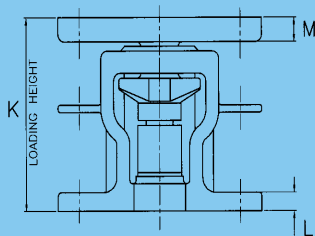
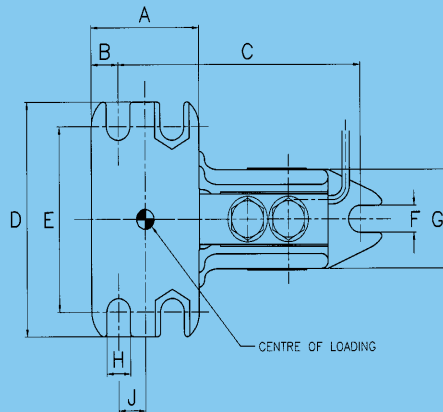

Capacity (kg)	A	B	C	D	E	F	G	H	J	K	L	M
20, 50, 100 & 200	70	16	147	100	80	9	55	9	19	80	7	8
300, 500, 1000, 2000	70	16	168	132	108	14	60	14	19	110	12	12
3000, 5000	100	25	225	190	150	22	80	22	25	164	15	20

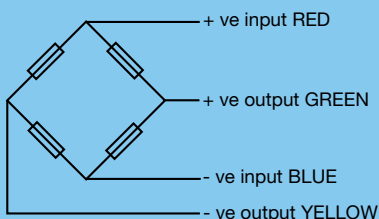

**Electrical Connections**  
 \*Via 4 core, 7/0.2mm (0.22mm<sup>2</sup>), screened polyurethane cable.

Screen is not connected electrically to the load cell.

UK Patent No. 2 339 026  
 US Patent No. 6 320 142

Our policy is one of continuous product enhancement. We therefore reserve the right to incorporate technical modifications without prior notification.  
 LeverMount® is a registered trade mark of Thames Side Sensors Limited.

**Distributed by**  
 Wessex Scale Co  
 Lower Mill, Exford Nr Minehead  
 Somerset TA24 7QE  
 Tel: 0845 472 5345  
 Fax: 01643 800 299  
 Email: sales@wessexscales.co.uk  
 Website: www.wessexscales.co.uk

