

Wessex Scale Co
Analytical Semi-Micro Balances

GR

Series

High Performance of up to 0.01mg Semi-Micro Weighing
Automatic Self-Calibration and Ergonomic Design

GR-202

210g x 0.1mg
42g x 0.01mg

GR-300

310g x 0.1mg

GR-200

210g x 0.1mg

GR-120

120g x 0.1mg



AND ...Clearly a Better Value

Superb "New Generation"

Speedy & Simple Operation to Maximize Performance

Easy Access Door

A unique system allows the user to conveniently open or close the left or right side of the weighing chamber using a control lever. This system allows quick and efficient access to the weighing chamber.



Open left or right side from front

One Touch Calibration

Allows quick calibration with one push of the CAL key.

Automatic Adjustable Environment Setting

Adapts automatically to the most suitable Environment Response Setting to minimize adverse external effects. "FAST", "MID" or "SLOW" is displayed.



Automatic Self Calibration

Performs self calibration automatically when a change of ambient temperature exceeds the preset temperature range.



13 Multiple Weighing Units

g, mg, pcs, %, oz, ozt, ct, mom, dwt, GN, tl, t (tola), m (messghal)

Two Layer Housing

Durable construction minimizes negative effects of ambient temperature changes.

Splash Proof Keyboard and Display

Protected from dust and spills.

Data Memory Function

Stores up to 200 sets of weighing data. Data can be output using numerical codes.



GLP/GMP Compliant

Allows GLP or LIMS balance management by outputting the Balance ID number and weight used to calibrate the balance. The data can be output to A&D's AD-8121B printer or a computer, indicating date, time, Balance ID number and calibration weight.

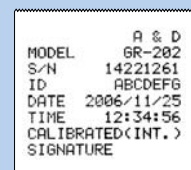

on" Analysis!



The GR Series has a 30% smaller footprint compared with conventional balances. Its tall weighing chamber can accommodate large beakers.



Standard Underhook

Ideal for density measurement and weighing magnetic substances

Standard RS-232C

Enables bi-directional communication with a PC or printer.

Quick Reference Card

A fast and convenient operation guide.



WinCT—Window Communication Tools

WinCT is Windows Communication Tools Software, providing easy transmission of weighing data from A&D Balances to a PC using RS-232C interface.

Data can be transferred in a manageable format limited only by a PC's capability.

WinCT consists of three applications:

- RsKey** allows weighing data to be directly pasted into a Windows application such as EXCEL or WORD, but this application cannot use "commands" to control the balance.
- RsCom** can transmit weighing data to a PC using a text file format and can transmit "commands" to control the balance. "Commands" include Calibrate, On/Off, Print, Query weight data, Re-zero, Range, Sample, Mode and Zero.
- RsWeight** can retrieve weighing data from a balance and display it in graph form on a PC screen in real-time. Maximum, minimum, average, standard deviation and coefficient of variation values of data can be calculated and displayed.

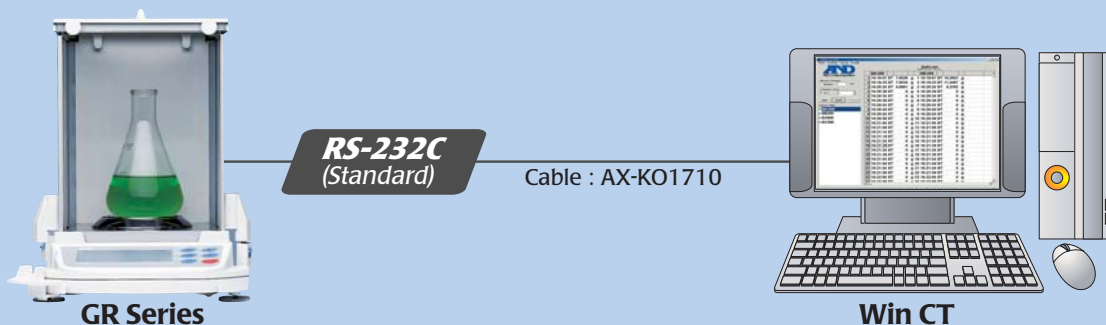

RsCom, RsKey and RsWeight offer user selectable time, date, sequential #, interval transmission and GLP/GMP data. A readme file contains all setup, operation & troubleshooting guides.

Specifications

		GR-202	GR-300	GR-200	GR-120
Gram	(g)	210 x 0.0001 / 42 x 0.00001	310 x 0.0001	210 x 0.0001	120 x 0.0001
	(mg)	210000 x 0.1 / 42000 x 0.01	310000 x 0.1	210000 x 0.1	120000 x 0.1
Decimal Ounce (oz)		7.4 x 0.00001 / 1.4 x 0.000001	10 x 0.00001	7.4 x 0.00001	4.2 x 0.00001
Troy Ounce (ozt)		6.7 x 0.00001 / 1.3 x 0.000001	9.9 x 0.00001	6.7 x 0.00001	3.8 x 0.00001
Pennyweight (dwt)		135 x 0.0001 / 27 x 0.00001	199 x 0.0001	135 x 0.0001	77 x 0.0001
Carat (ct)		1050 x 0.001 / 210 x 0.0001	1550 x 0.001	1050 x 0.001	600 x 0.001
Momme (mom)		56 x 0.0001 / 11 x 0.00001	82 x 0.0001	56 x 0.0001	32 x 0.0001
Grain Unit (GN)		3240 x 0.002 / 648 x 0.0002	4784 x 0.002	3240 x 0.002	1851 x 0.002
Tola (t)		18 x 0.00001 / 3.6 x 0.000001	26 x 0.00001	18 x 0.00001	10 x 0.00001
Tael (TL)		5.5 x 0.00001 / 1.1 x 0.000001	8.2 x 0.00001	5.5 x 0.00001	3.1 x 0.00001
Percentage Min Div.		0.01%			
Counting Min Weight		0.1mg			
Linearity		±0.0002 / ±0.00003g	±0.0003g	±0.0002g	
Repeatability/Std. Dev.		0.0001 / 0.00002g	0.0002g	0.0001g	
Stabilization Time		3.5 / 8 seconds (typically)	3.5 seconds (typically)		
Sensitivity Drift		±2ppm / °C (10°C~30°C / 50°F~86°F)			
Display Refresh		5 times per second / 10 times per second			
Pan Size		Ø85mm / 3.3inches			
Physical Dimensions	mm	249 (W) x 330 (D) x 328 (H)			
	inches	9.8 (W) x 12.99 (D) x 12.91 (H)			
Breeze Break Dimensions	mm	178 (W) x 160 (D) x 233 (H)			
	inches	7.01 (W) x 6.5 (D) x 9.17 (H)			
Admissible Ambient Conditions		5°C~40°C / 41°F~104°F RH less than 85%			
Weight Approximately		6.0kg / 13.2lb			
Power		Approx. 11VA (supplied to the AC adapter)			
Standard Accessories		WinCT in CDROM, Manual, AC Adapter, Reference Card			

Specifications are subject to change for improvement without notice

Accessories

- AD-1653** Density Determination Kit
- AD-8121B** Compact Printer
- AD-1651** Vibratory Spoon
- AD-1682** Rechargeable Battery Unit
- AD-1683** Static Eliminator
- AD-8920** Remote Display
- AD-8922** Remote Controller
- AD-8526** RS/Ethernet Converter with WinCT-Plus
- AX-KO1710** RS-232C Cable (25P-9P)

AD-1653 / Optional Density Determination Kit



GR Series Dimensions (mm / inches)

TOP VIEW

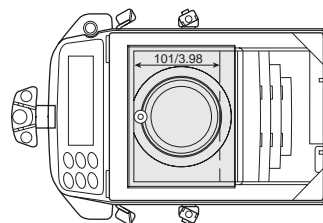

REAR VIEW

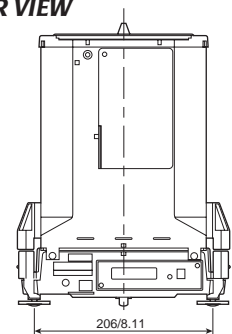

FRONT VIEW

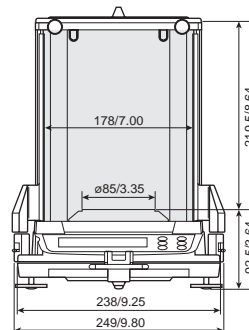

SIDE VIEW

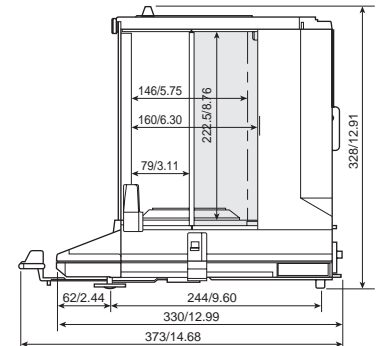

Supplied by:

Wessex Scale Co, Lower Mill, Exford Nr Minehead Somerset TA24 7QE
 Tel: 0845 472 5345 Fax: 01643 800 299 Email: sales@wessexscales.co.uk
 Website: www.wessexscales.co.uk