

Model BM+32T

The 'Berkel Mincer Plus 32T Range' has been designed for larger independent food retail outlets and chains, supermarket groups, and hypermarkets.

The range consists in two table top models.

The 32 is available in both single phase and three phase, all models are constructed from stainless steel.

DESCRIPTION		
Model Range		
BM+32T		
SPECIFICATIONS		
Finish		
The Mincer is constructed from stainless steel.		
Mincer head type		
32		
		
Working Position	Product Capacity	Approvals
Table Top	Refer to specification matrix overleaf.	CE Conformity: is in accordance with EEC directive 98/37, 89/336, 73/23, 89/109.
Through-put	Environment	
700 kg/h	The machine should be cleaned at least once a day. High-pressure water and steam cleaning should NOT be used.	
Product Worked	Cutting System	
Fresh and semi-fresh meat	Enterprise system	
Product Limitations		
The following products should not be worked on the BM+32T: - Forzen meat - Meat with bone - Non food products		

DIMENSION CHART

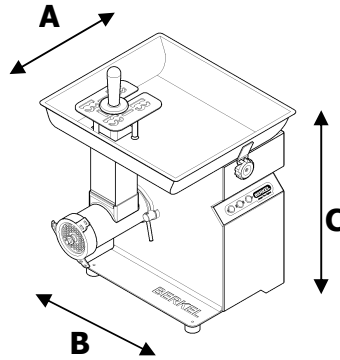

DIMENSIONS

Model	BM+32T
A mm	428 mm
B mm	470 mm
C mm	510 mm

SPECIFICATIONS

Model	BM+32T
Model type	32
Working Position	Table top
Through-put	700 kg/h
Electrical specification	230V 50Hz 1 phase or 400V 50Hz 3 phase
Motor specification	2,2 kW
Overall dimension (lxwxh)	428x470x510h mm
Net weight	65 kg

Options:

- Medium legs with lockable wheels
- Long legs with lockable wheels
- Retractable tray
- Large hopper (tray) (30 litre)
- Extra large hopper (tray) (60 litre)
- 3 piece Unger (instead of standard Enterprise system)
- 5 piece Unger (instead of standard Enterprise system)

SHIPPING SPECIFICATIONS

Model	Crate Dimensions			Gross Weight
	Length	Width	Height	
BM+32T	640 mm	760 mm	850 mm	80 kg