



# Adventurer™ Pro

Analytical and Precision Balances



## ***The Ohaus Adventurer™ Pro – The Most Complete Balance in Its Class!***

The Ohaus Adventurer™ Pro is one of the industry's most versatile balances - it counts, it sums, it holds and it delivers traceable results. With a full range of Analytical and Precision models, no other balance in its class offers all these features in a compact design:

- **Easy Access, Frameless Draughtshield with Removable Doors** – All doors, including the front and back glass panels, disassemble in seconds, and together with a stainless steel base, make it fast and easy to clean.
- **SmarText™ Software Guides Users Through Balance Use** – SmarText™ is Ohaus' easy to use balance software that utilises text prompts to guide users through applications and balance setup.
- **QuadraStance™ Design Provides Superior Footprint Stability** – To enhance weighing stability, QuadraStance incorporates four feet to provide superior footprint stability on any surface.
- **Flexibility of Available Options** – Ensure weighing accuracy with InCal™ internal calibration. A factory installed USB or second RS232 interface allows connection to multiple peripherals.
- **EC Type Approved models available**

# Adventurer™ Pro Balances

## Frameless Draughtshield With Removable Doors Provides Convenient Access



Users frustrated by navigating tight spaces will welcome the easy-access weighing chamber of the Adventurer Pro. The draughtshield is designed without the need of top rails, so users have unobstructed entry to place or retrieve materials to be weighed. With such unobstructed entry, the chance for accidental spillage is reduced helping to eliminate waste.



With contamination being a concern in today's work environment, all doors, including the front and back glass panels are simple to remove and replace for fast and easy cleaning. Should breakage occur, within 3 easy steps, each replacement door and panel can be installed in seconds.



## SmarText™ Software Brings Man and Machine Together

SmarText™ is Ohaus' easy to use balance software that utilises text prompts to guide users through applications use and balance setup. Delivered through a 2-line backlit LCD and clearly marked buttons, SmarText tells you what is going on and what you have to do next.



Utilising the 2-line LCD, SmarText simultaneously displays weight and application specific information such as percent or count. For example, with one touch of the Function button, SmarText will display application reference information such as average piece weight (APW), while displaying a parts count.



## QuadraStance™ Design for Superior Stability

QuadraStance™ incorporates four adjusting feet to provide superior footprint stability on any surface. QuadraStance helps prevent rocking and tipping, enhancing the weighing stability of the balance, and keeping the Adventurer *Pro* level and accurate.

Additionally, Adventurer *Pro* has been designed with a front level indicator eliminating the need to look behind the balance during the leveling process. A quick glance at the level indicator helps to ensure that the balance is level prior to each use.



## Added Flexibility of Available Options

The Adventurer *Pro* also offers InCal™ internal calibration. InCal ensures weighing accuracy by allowing you to calibrate the balance prior to use without the need of external weights.

All Adventurer *Pro* models come with a built-in RS-232 interface, and for added functionality can be equipped with either a second RS-232 or USB interface, allowing connections to multiple peripherals. With full GLP/GMP data output, Adventurer *Pro* can meet traceability and compliance requirements.



## Other Standard Features Include:

### Multiple Application Modes Including:

- Dynamic Weighing Mode – Allows the user to weigh small animals and filters out animal movements to provide a stable weight indication
- Parts Counting with Optimisation – Allows the user to count based on a calculated piece weight. With optimisation, counting accuracy is improved through auto re-calculation of the piece weight
- Percentage Mode – Allows the user to display the weight of a sample as a percentage of a reference weight
- Checkweighing Mode – Allows the user to check the weight of a sample against a preset target
- Totalisation Mode – Allows allows the user to sum a series of sample weights
- Display Hold Mode – Allows the user to hold the highest stable weight on the display until cleared



### Selectable Environmental Settings

- Three filter modes and adjustable zero tracking are ideal for working in slow filling applications where sensitivity is a must. When working in harsh environments, the user can adjust balance settings to compensate for vibrations and other disturbances.

### Protective In-Use Cover

The in-use cover is replaceable and offers protection against dust and debris, minimising the chance of damage to the display and keypad buttons.

# Adventurer™ Pro Balances

**Feature Rich: Adventurer Pro Is The Most Complete Balance In Its Class**

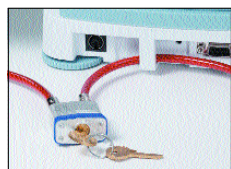

#### **Security**

To prevent unwarranted movement or theft, an integrated security bracket

accommodates the security device accessory

#### **Easy to Clean**

Adventurer Pro's stainless steel platform and removable wind ring make it extremely easy to clean



#### **Connectivity**

Adventurer Pro comes with an RS232 interface. A second RS232 or

USB interface is also available as a factory installed option

#### **Easy to View Display**

Adventurer Pro features a 2-line alphanumeric LCD with brilliant backlight. Portable models include a backlight auto-off feature to conserve battery life

#### **AC and / or Battery Power**

Some models offer portability and can operate on either the included AC adapter, or on 4 "AA" batteries. An Auto Shutoff feature helps conserve battery life



#### **Weigh-Below Hook**

Adventurer Pro's integral weigh-below hook allows density determination or calculating the specific gravity of samples



#### **Multiple Weighing Units**

Adventurer Pro features multiple weighing units including a user-defined custom unit for use in unique weighing applications

#### **Easy to Use Keypad**

Four-button keypad with dedicated YES, NO, BACK and EXIT functions simplify menu navigation and balance set-up

Supplied by

Wessex Scale Co

Lower Mill, Exford Nr Minehead Somerset TA24 7QE

Tel: 0845 472 5345 Fax: 01643 800 299

Email: [sales@wessexscales.co.uk](mailto:sales@wessexscales.co.uk)

Website: [www.wessexscales.co.uk](http://www.wessexscales.co.uk)

## General Specifications

Weighing Units*	Milligram, Gram, Kilogram, Ounce, Pound, Carat, Pennyweight, Ounce Troy, Grain, Newton, Hong Kong Tael, Singapore Tael, Taiwan Tael, Momme, Tical, Baht, Mesghal, Tola, Custom
Application Modes	Weighing, Dynamic Weighing, Parts Counting with Automatic Sample Recalibration, Percent Weighing, Checkweighing, Totalisation, Display Hold
Tare Range	To capacity by subtraction
Operating Temperature Range	10° - 30°C
Calibration	Digital with External Weight (non-"C" models) Digital with Internal Weight ("C" models with InCal option)
Display Type	2-Line Alphanumeric Backlit LCD Display
Display Size (in/cm)	10 x 2.5

\* Milligram unit available on 0.1mg to 1mg models  
Kilogram and Pound units available on 0.01g to 0.1g models

## Technical Specifications, Precision Balances

Capacity (g)	210	310	410	210	410	810	2100	3100	4100	2100	4100	8100
Readability (g)	0.001			0.01			0.01			0.1		
Approved Readability (g) (...M models only)	0.01			0-50 / 51-210 0.01 / 0.02	0-50 / 51-410 0.01 / 0.05	0.1			0-500 / 501-2100 0.1 / 0.2	0-500 / 501-4100 0.1 / 0.5	1	
Repeatability (Std. dev.) (g)	0.001			0.01			0.01			0.1		
Linearity (g)	± 0.002			± 0.02			± 0.02			± 0.2		
Stabilisation Time (seconds)	3			1.5*	3			2*				
Power Requirements w/ InCal	AC Adapter (Included)											
Power Requirements w/o InCal	AC Adapter			AC Adapter (Included) or 4 AA Batteries (not included)			AC Adapter			AC Adapter (Included) or 4 AA Batteries (not included)		
Draughtshield Type with Height Over Pan (cm)	Square: 11.5	None										
Pan Size with InCal (cm)	12 dia.				16.8 x 18							
Pan Size without InCal (cm)	12 dia.				14.9 x 16.2		16.8 x 18		14.9 x 16.2			
Balance Dimensions w/ InCal W x H x D (cm)	22 x 19 x 30	22 x 8.5 x 30										
Balance Dimensions w/o InCal W x H x D (cm)	22 x 19 x 30			19.3 x 7.2 x 25.4			22 x 8.5 x 30			19.3 x 7.2 x 25.4		
Shipping Dimensions w/ InCal W x H x D (cm)	39 x 41 x 50			39 x 33 x 50								
Shipping Dimensions w/o InCal W x H x D (cm)	39 x 41 x 50			27.6 x 16 x 38.5			39 x 33 x 50			27.6 x 16 x 38.5		
Net Weight w/InCal (kg)	3.7		2.6	3.4		3.2			3.5			
Net Weight w/o InCal (kg)	3.3		1.2	1.5		2.8			1.6			
Shipping Wt w/ InCal (kg)	6.6		5.4	6.2		6.1			6.3			
Shipping Wt w/o InCal (kg)	6.2		2.2	2.4		5.7			2.5			
Item Number w/ InCal Internal Calibration	AV213C	AV313C	AV413C	AV212C	AV412C	AV812C	AV2102C	AV3102C	AV4102C	AV2101C	AV4101C	AV8101C
Item Number w/o InCal Internal Calibration	AV213	AV313	AV413	AV212	AV412	AV812	AV2102	AV3102	AV4102	AV2101	AV4101	AV8101
Item Number EC Type Approved w/o InCal Internal Calibration**	---	---	---	AV212DM	AV412DM	AV812M	---	---	---	AV2101DM	AV4101DM	AV8101M
Item Number EC Type Approved w/ InCal Internal Calibration	AV213CM	---	AV413CM	AV212CDM	AV412CDM	AV812CM	AV2102CM	---	AV4102CM	AV2101CDM	AV4101DM	AV8101CM

\*Note: Models AV212C, AV2101C, AV4101C and AV8101C have a stabilization time of 3 seconds

\*\*Requires 2nd stage verification on place of use by authorised organisation

Note: EC type approved class II, approval no.: D05-09-029 or D04-09-033

## Outline Dimensional Drawings, Precision Balances

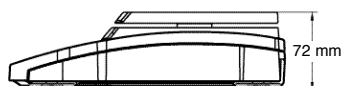

Models AV212, AV412, AV812, AV2101, AV4101, AV8101

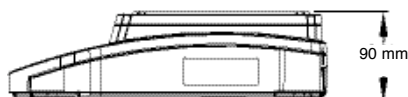

Models AV2102, AV3102, AV4102

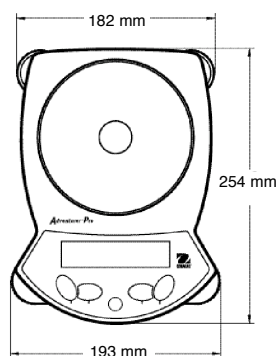

Models AV212, AV412, AV812, AV2101, AV4101, AV8101

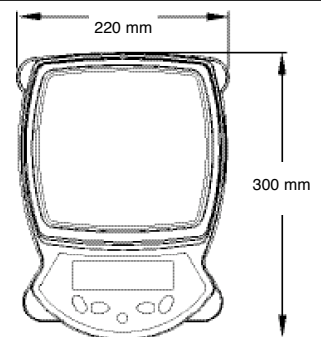

Models AV213, AV213C, AV313, AV313C, AV413, AV413C, AV212C, AV412C, AV812C, AV2102, AV2102C, AV3102C, AV4102, AV4102C, AV2101C, AV4101C, AV8101C

Models AV212, AV412, AV812, AV2101, AV4101 and AV8101 feature battery capability and a full protective in-use cover