

TSCALE

SCALES & BALANCES

Wessex Scale Co

T28 SERIES WEIGHING SCALE



TECHNICAL DATA

- ◆ External resolution..... 6,000
- ◆ Display.....25 mm LCD, attached LED backlight
- ◆ Pan size.....230mm×190mm
- ◆ Keyboard.....3 keys
- ◆ Operate temp.....0°C ~ +40°C
- ◆ ADC update.....≤ 1/10 second
- ◆ Rating.....Dry battery (size D x 3)(T20)
9V AC adapter or Rechargeable
battery (6V/4Ah)(T28)

FEATURES

- ◆ 25mm LCD display, attached LED backlight
- ◆ AC adapter/ rechargeable battery powered
- ◆ Selectable weighing unit (kg/lb)
- ◆ Standard Stainless Steel top pan
- ◆ Waterproof housing designed, rugged and dependable
- ◆ Battery provide up to 90 hours of continuous use

DIMENSIONS (mm)

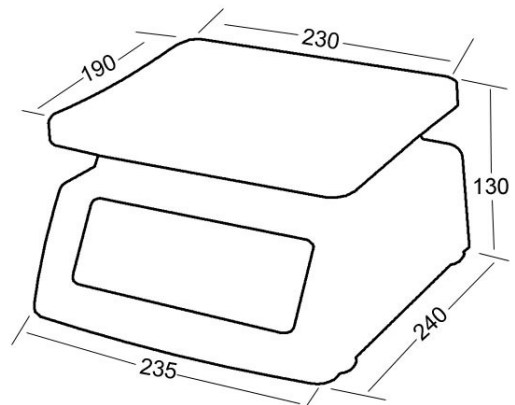

SPECIFICATIONS

Model	T28
Capacity/division	3kg/0.5g, 6kg/1g, 15kg/2g
Pan size	190mm x 230mm
Display	25mm LCD , attached LED backlight
Internal counts	200,000
Rating	Rechargeable battery (6V/4Ah) or 9V AC adapter
Gross weight	3.5kg

Supplied by,

Wessex Scale Co, Lower Mill, Exford Nr Minehead Somerset TA24 7QE

Tel: 0845 472 5345 Fax: 01643 800 299 Email: sales@wessexscales.co.uk

Models and specifications to change without notice